

K58TX



Montaboette a tracciatori

La K58TX nasce come naturale evoluzione della storica macchina K58STI.

Il sistema di spalmatura di collante termoplastico direttamente sul sottopiede avviene tramite tracciatori.

Grazie all'utilizzo del controllo elettronico completo della macchina vengono inoltre memorizzate tutte le funzioni ciclo, i tempi, i dati di incollaggio per l'intera numerata.

SETTORI DI APPLICAZIONE



Uomo



Donna



Bambino



Safety



Sportive



Sneakers Montato



Spalmatura del collante termoplastico direttamente sul sottopiede



Sistema di programmazione con Touch Screen 7" con archivio programmi su chiavetta USB, funzioni di autodiagnostica

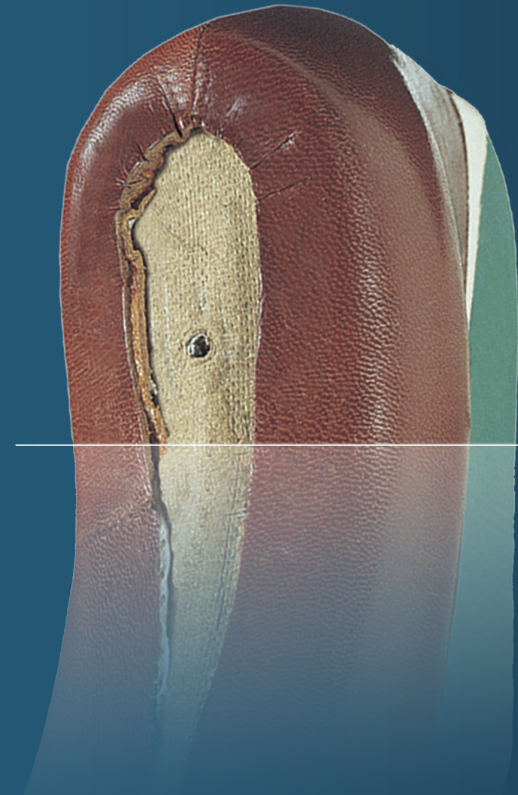

K58TX



Tracers heel seat lasting machine

The K58TX born on the natural evolution of the well known K58STI. The cement is applied by tracers directly on the insole. Thanks to the full electronic control of the machine, all cycles settings, timers, cementing data for all sizes.

SECTORS OF APPLICATION



Man



Woman



Child



Safety



Sports



Lasted Sneakers



Thermocement application by tracers directly on the insole



7" Touch screen programming system with styles storage on USB key, autodiagnostic functions

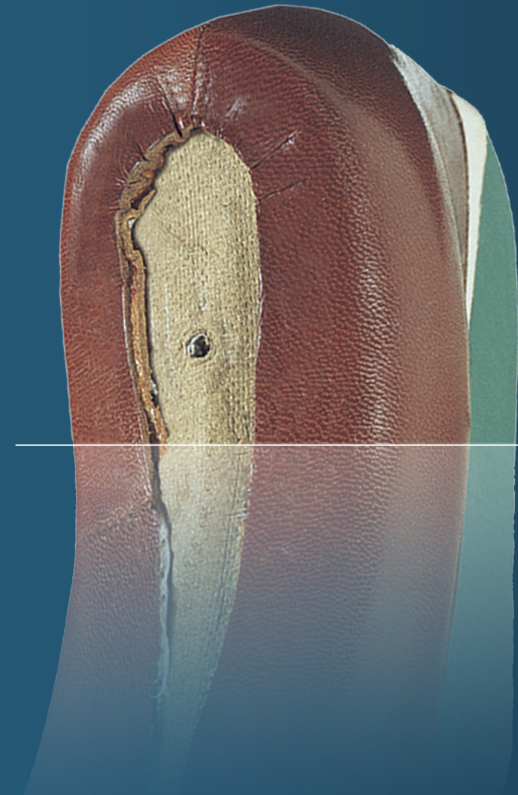

CARATTERISTICHE TECNICHE

K58TX

DIMENSIONI	mm 950 x 1300 x 1900
DIMENSIONI IMBALLO	mm 1050 x 1400 x 2100
PESO NETTO	Kg 640
PESO LORDO IN CASSA	Kg 780
POTENZA ELETTRICA TOTALE INSTALLATA	Kw 2,0
ALIMENTAZIONE PNEUMATICA	Bar 6

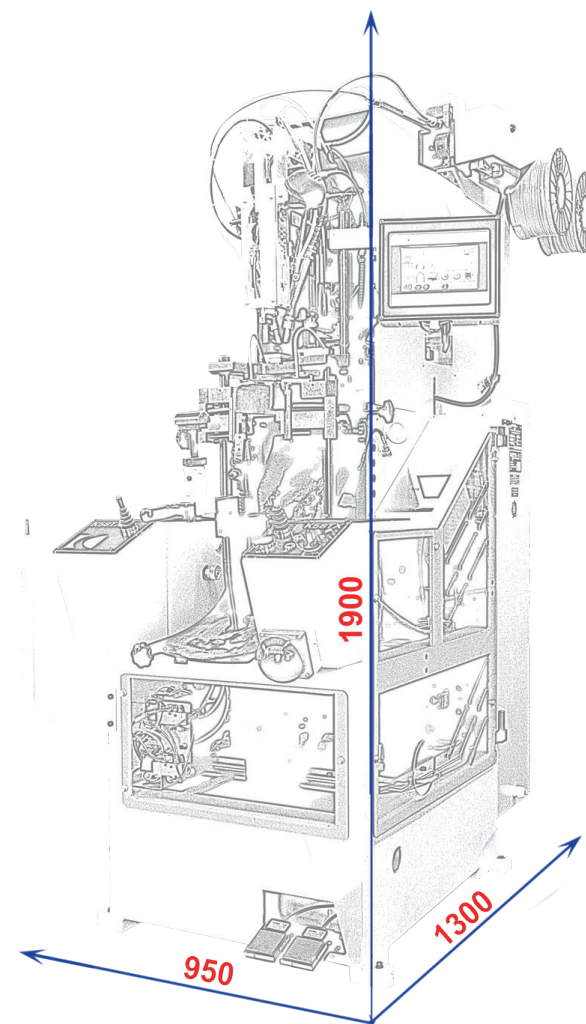

TECHNICAL FEATURES

K58TX

DIMENSIONS	mm 950 x 1300 x 1900
PACKAGING DIMENSIONS	mm 1050 x 1400 x 2100
NET WEIGHT	Kg 640
GROSS WEIGHT IN CASE	Kg 780
TOTAL INSTALLED ELECTRIC POWER	Kw 2,0
PNEUMATIC POWER SUPPLY	Bar 6

